

Research on Real Time Tractor Monitoring and Operational Visualization

Prof A. U. Chaudhari¹, Ninad Dhananjay Lad², Danish Ahemad Shaikh Nasir³, Mohammad Mudassir Qureshi⁴, Deep Pramod Singapure⁵, Parth Dilip Marotkar⁶

¹Assistant Professor, CSE, Prof. Ram Meghe Institute of Technology & Research, Badnera

^{2,3,4,5,6}Student, CSE, Prof. Ram Meghe Institute of Technology & Research, Badnera

Abstract: Agriculture is undergoing a major transformation with the integration of automation, IoT, and smart monitoring systems. Conventional tractor operations often demand continuous human supervision, leading to increased labor costs, inefficiency, and errors in field operations. With the advent of embedded systems and intelligent software platforms, there is now a growing need for solutions that can automate routine tasks, provide real-time monitoring, and deliver actionable insights to farmers. The proposed paper, Real Time Tractor Monitoring and Operational Visualization System, is designed as a smart embedded software integration model to support precision agriculture. The hardware prototype is developed using an ESP8266 microcontroller, ESP32 camera module, L298 motor driver, and 4 BO motors with wheels, enabling the vehicle to autonomously navigate along a path. A color-based navigation mechanism is implemented, where a fixed color (e.g., red) is detected using image processing to guide the tractor from one point to another. If the tractor deviates from its assigned path, a notification is immediately sent to the user through a Firebase database and displayed on the web application.

Keyword: IoT, Embedded System, Real Time Monitoring, Software, Image Processing, Web Application, Flask.

I. INTRODUCTION

Agriculture is the backbone of many economies, and with the rapid growth of population, there is a continuous demand to increase food production while reducing labor dependency. Traditional farming practices often require significant manual effort and supervision, particularly in tractor-based operations such as seeding, monitoring, and field management. The advancement of embedded systems, Internet of Things (IoT), and image processing technologies has opened new opportunities to automate these agricultural activities and provide real-time operational insights to farmers.

The proposed Real-Time Tractor Monitoring and Operational Visualization System is an innovative approach that combines embedded hardware with a software-based visualization platform to enhance efficiency in agricultural operations. A prototype tractor is developed using an ESP8266 microcontroller, ESP32 camera module, 4 BO motors, and an L298 motor driver to simulate autonomous movement across the farm. A color detection mechanism is integrated, where the tractor identifies a predefined color logo/symbol (e.g., red) to navigate from one point to another using image processing. Any deviation from its assigned path triggers an instant alert through the Firebase database, which is displayed on a mobile-responsive Flask-based web application.



Furthermore, the system provides continuous updates regarding seeded and occupied areas of the farm, allowing farmers to visualize operations in real time. By integrating IoT, computer vision, and embedded technology, the paper aims to reduce manual supervision, improve field productivity, and move towards the concept of smart farming in a cost-effective manner.

II. LITERATURE REVIEW

[1] Terence Irumva et al., In this paper the author presents a real-time operator safety system using machine learning. The system monitors agricultural machinery operators through sensors and cameras to detect unsafe behaviors, fatigue, or distraction. By providing timely alerts, it helps prevent accidents and enhances overall safety, contributing to safer and more efficient farming operations.

[2] Amandeep Singh et al., In this paper the author presents an IoT-based system to monitor tractor vibrations in real time. The system alerts operators when vibration levels exceed safe limits, helping reduce fatigue and musculoskeletal risks, thereby improving safety and well-being.

[3] Delorme Correa Junior et al., In this paper shows an embedded system that monitors tractor wheel slippage and fuel usage in real time. The system provides insights to optimize performance, reduce fuel consumption, and improve operational efficiency.

[4] Phasinam et al., In this paper the author introduces a cost-effective solution for tracking agricultural tractors. The system integrates Differential GPS (DGPS) technology with Internet of Things (IoT) devices to provide accurate real-time positioning. This approach enhances operational efficiency by enabling precise navigation and monitoring of tractor activities, making it a valuable tool for precision agriculture.

[5] Elijah et al., In this paper the author provides a comprehensive review of how IoT and data analytics are transforming agriculture. The authors discuss the integration of technologies such as wireless sensor networks, RFID, and cloud computing to enable smart farming practices. They highlight benefits like improved resource management, increased crop yields, and enhanced decision-making. However, challenges such as data privacy, interoperability, and infrastructure limitations are also addressed. The paper emphasizes the need for future innovations and solutions to overcome these challenges and fully realize the potential of IoT in agriculture.

[6] Loutridis, S et al., In this paper the author shows how electronic engine speed regulation impacts tractor ride vibrations. The research reveals that while electronic speed control can increase vibration levels during transportation on asphalt roads, it offers advantages in field tasks like cultivating by reducing vibration exposure. The findings suggest that electronic speed regulation should be used judiciously, considering the specific operational context to optimize operator comfort and safety.

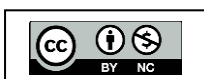



[7] Kumar AA et al., In this paper the author introduces a Hall-effect sensor-based system to measure wheel slip in agricultural tractors. The system integrates a microcontroller to display real-time slip data and provides audible and visual alerts when slip exceeds optimal levels. Field trials demonstrated that the device could be retrofitted to various tractor models, offering significant fuel savings—up to 1.3 liters per hour—by promoting efficient operation and reducing soil compaction.

[8] Lanças KP et al., In this paper the author provides a comprehensive overview of standardized procedures for evaluating agricultural tractors. The authors emphasize the importance of these tests in obtaining reliable and impartial information about tractor performance, which is crucial for optimizing agricultural operations. They discuss various methodologies and advancements in testing, highlighting the role of modern technologies in enhancing the accuracy and efficiency of tractor evaluations. The study underscores the need for continuous development of testing protocols to keep pace with innovations in agricultural machinery.

[9] Choosumrong S. et al., In this paper the author introduces an IoT-based system for real-time agricultural monitoring and irrigation control. The system utilizes wireless sensor networks (WSNs) to collect environmental data such as temperature, humidity, and soil moisture. This data is then processed and displayed through a mobile application, allowing farmers to monitor and manage irrigation remotely. The integration of IoT technology facilitates efficient water usage and timely interventions, thereby promoting sustainable agricultural practices.

[10] Sharma K. et al., In this paper the author shows the transformative impact of combining AI and IoT technologies in agriculture. The authors discuss how IoT facilitates real-time data collection through sensors, while AI algorithms analyze this data to optimize crop management practices. The integration enables precise monitoring of soil conditions, weather patterns, and crop health, leading to informed decision-making and resource-efficient farming. The paper highlights the potential of this synergy to revolutionize precision agriculture by enhancing productivity and sustainability.

III. METHODOLOGY

The proposed system is an IoT-enabled tractor monitoring and visualization solution that integrates embedded hardware with a responsive software platform to support smart farming. The hardware prototype is developed using an ESP8266 microcontroller, ESP32 camera module, 4 BO motors, and an L298 motor driver, which together enable autonomous tractor movement. A color based navigation technique is employed, where the ESP32 camera detects a predefined logo/symbol color, such as red, to guide the tractor from one location to another. In case the tractor deviates from its designated path, the system instantly generates a notification that is transmitted through the Firebase database to the user's web application.

The software component is implemented using the Flask framework, designed to be mobile-responsive, and provides real-time visualization of tractor operations, seeded regions, and occupied farm areas. By combining embedded technology, computer vision, and IoT communication, the system

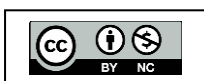

reduces manual supervision, improves monitoring accuracy, and offers a practical step toward implementing precision agriculture and smart farming practices.

A. Block Diagram

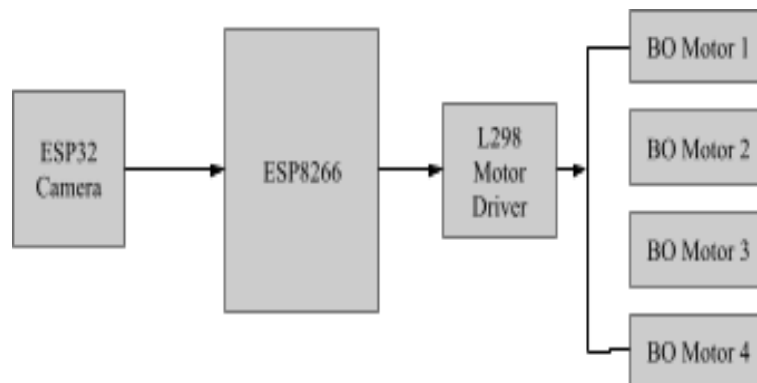

Figure 1: Shows the Block Diagram of the System

B. Flow Chart

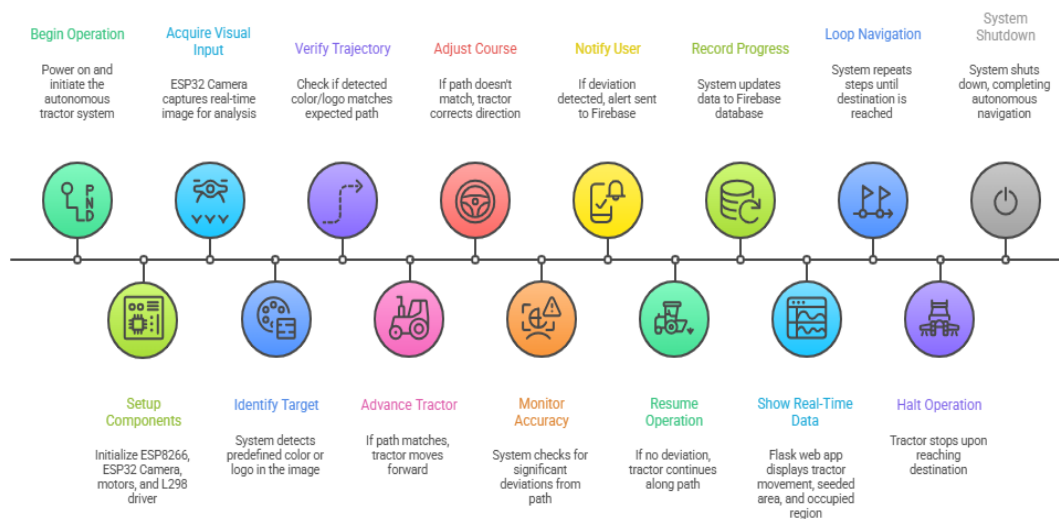
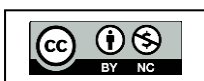

Figure 2: Shows the Flow Chart of the System

C. Working

The system operates by integrating embedded hardware with real-time software monitoring to enable autonomous tractor movement. The ESP8266 microcontroller controls the tractor's motors through the L298 motor driver, while the ESP32 camera continuously captures visual input from the field. Using color-based image processing, the system detects a predefined path color and guides the tractor accordingly. During operation, the tractor's movement and field



status are transmitted to a Firebase database through IoT communication. If the tractor deviates from the intended path, an alert is immediately generated and displayed on a Flask-based mobile-responsive web application. This enables users to monitor tractor activity, seeded areas, and occupied regions in real time, ensuring efficient and reliable agricultural operations.

IV. SYSTEM REQUIREMENTS

A. Hardware Requirements

- 1) ESP8266
- 2) ESP32 Camera Module
- 3) BO Motors * 4
- 4) L298 Motor

B. Software Requirements

- 1) Frontend: Html & Css
- 2) Backend: Python(Flask)
- 3) Arduino Ide
- 4) Proteus

V. EXPERIMENTAL SETUP & RESULT

The preferred spelling of the word “acknowledgment” in America is without an “e” after the “g”. Avoid the stilted expression “one of us (R. B. G.) thanks ...”. Instead, try “R. B. G. thanks...”. Put sponsor acknowledgments in the unnumbered footnote on the first page.

A. Experimental Setup

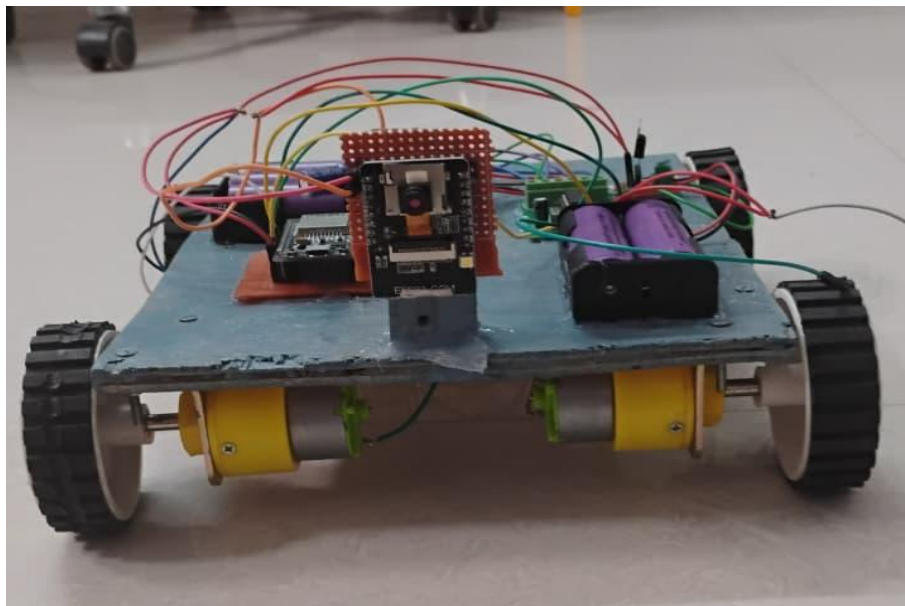

Figure 3: Shows the Front View of the Proposed System

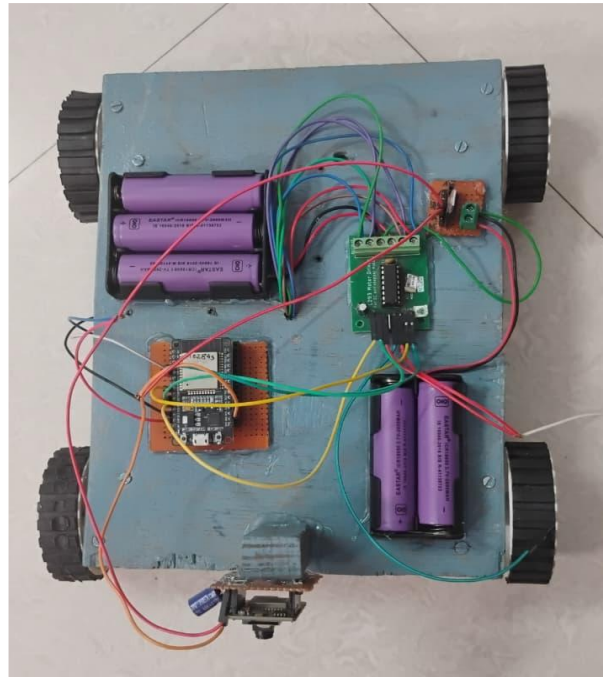

Figure 4: Shows the Top View of the Proposed System

B. Result

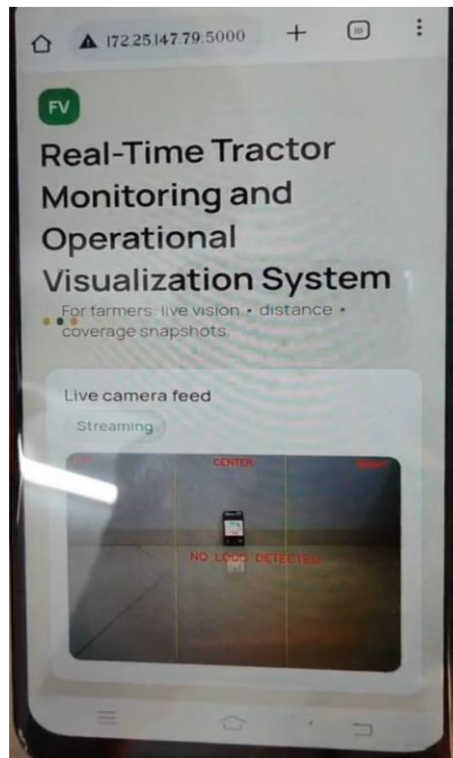

Figure 5: Shows the Live Camera Feed Window

The live camera feed window shows that the “No Logo Detected” and “it is at center position”.



Figure 6: Shows the Tractor Deviates from Path

The image illustrates that the tractor deviates from its designated path due to its inability to detect the red-colored logo or symbol, resulting in a loss of guidance.

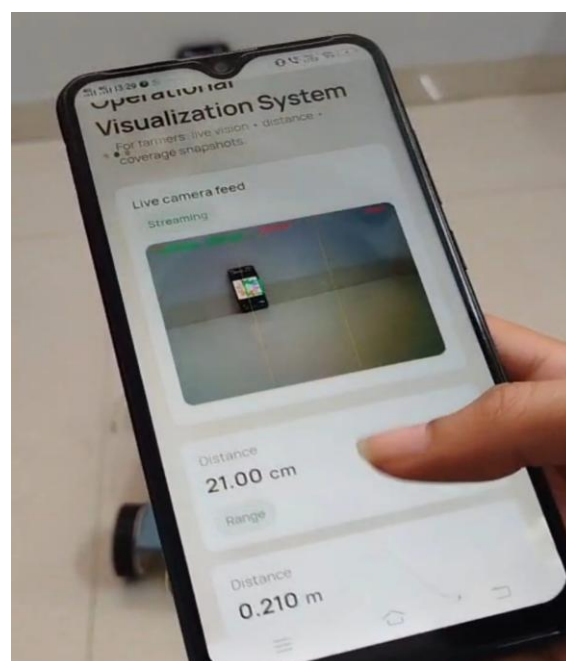

Figure 7: Shows the Distance of Tractor

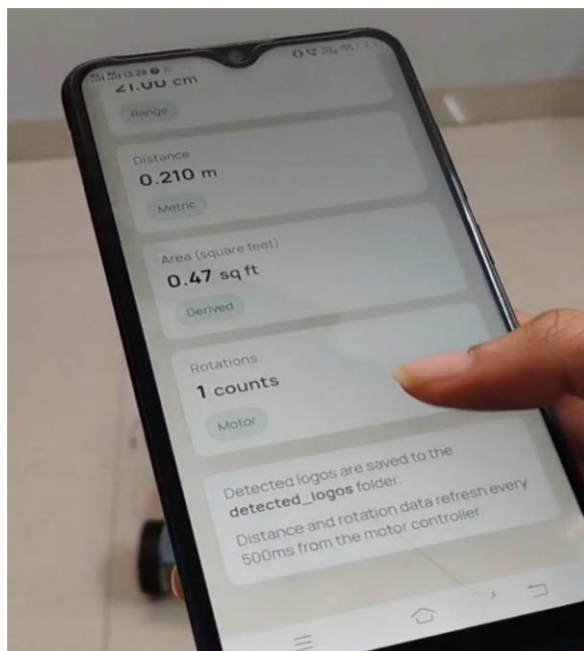

Figure 8: Shows the Area & Rotation Count of Tractor

Figure 7 & 8 Shows that when the truck deviates from its designated path then the system instantly generates a notification that is transmitted through the Firebase database to the user's web application. The alert includes key parameters such as Distance (21.00 cm), Area (0.47 sq ft), Rotations (1 count).

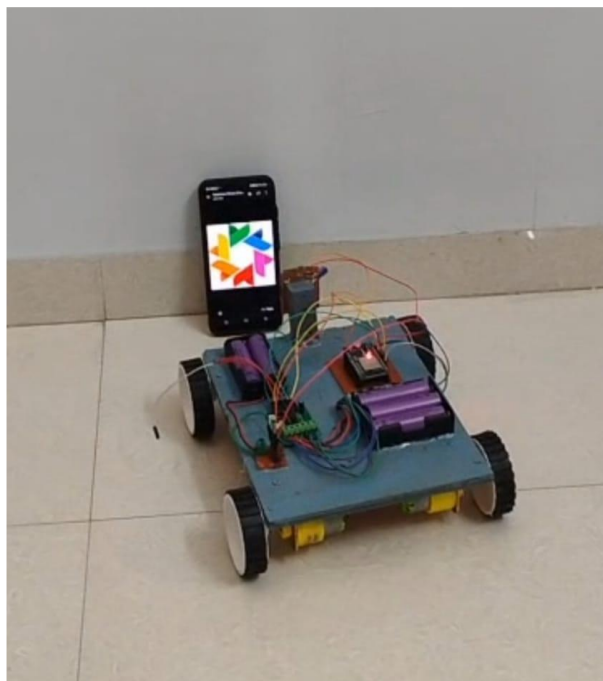

Figure 9: Shows the Tractor Detected Red Color Logo/ Symbol

The image displays that the truck recognizes the red color logo/ symbol which guides the tractor to move from one location to another location.

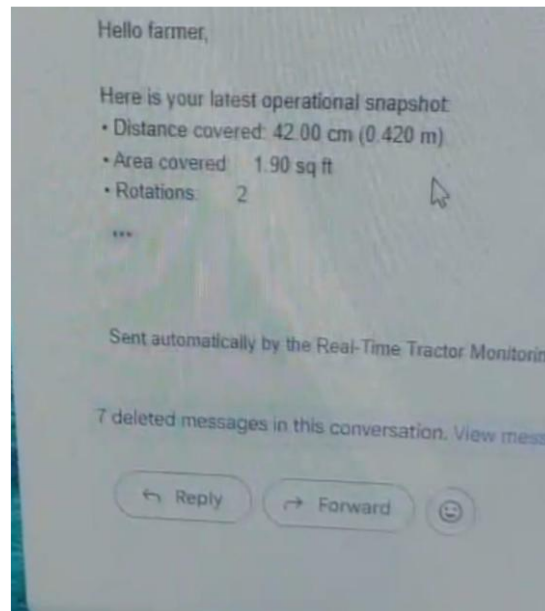

Figure 10: Shows the Received Email

The image shows the email received by the farmer. As the truck deviated from its designated path, the system sent an email notification to the farmer including all the details. The developed system successfully demonstrated autonomous tractor movement with effective real-time monitoring and visualization. The color-based navigation approach enabled accurate path following, while instant alerts were generated whenever deviations occurred. The Flask-based web application reliably displayed tractor status and farm activity updates, confirming the system's ability to reduce manual supervision and improve operational efficiency in agricultural environments.

VI. CONCLUSION

The Real-Time Tractor Monitoring and Operational Visualization System successfully integrates embedded hardware, IoT technology, and computer vision to provide an efficient solution for modern agricultural operations. By combining the ESP8266 microcontroller, ESP32 camera module, BO motors, and L298 motor driver with a Flask-based mobile-responsive web application, the system enables autonomous tractor navigation, real-time monitoring, and instant notifications in case of path deviations. The color-based navigation mechanism ensures accurate movement between predefined points, while the web application provides a clear visualization of tractor activity and seeded or occupied farm areas. Overall, this system reduces manual supervision, enhances operational efficiency, and demonstrates the potential of smart farming solutions, paving the way for increased productivity and better farm management.

**REFERENCES**

- [1] T. Irumva, H. Muwanguzi, S. Pitla, B. Lowndes, and A. Yode, "Agricultural machinery operator monitoring system (Ag-OMS): A machine learning approach for real-time operator safety assessment," *Biological Systems Engineering*, 2023.
- [2] A. Singh, N. Nawayseh, S. Samuel, Y. K. Dhabhi, and H. Singh, "Real-time vibration monitoring and analysis of agricultural tractor drivers using an IoT-based system," Wiley, May 4, 2023.
- [3] D. C. Junior, B. H. G. Barbosa, A. C. Marques Filho, C. E. S. Volpato, F. O. de Paula, D. H. C. Andrade, G. H. O. Fontes, R. R. Magalhaes, and D. D. Ferreira, "Embedded system for real-time monitoring of agricultural tractors slipping and fuel consumption," *Engenharia Agrícola*, Jun. 17, 2024.
- [4] P. Phasinam, P. U-kaew, P. Piyathamrongchai, H. Hataitara, R. Raghavan, T. Nemoto, and S. Choosumrong, "Real-time monitoring and positioning of agricultural tractors using a low-cost GPS and IoT device," *International Journal of Geoinformatics*, Jan. 2025.
- [5] O. Elijah, T. A. Rahman, I. Orikumhi, C. Y. Leow, and M. Hindia, "An overview of Internet of Things (IoT) and data analytics in agriculture: Benefits and challenges," *IEEE Internet of Things Journal*, 2018.
- [6] S. Loutridis, T. Gialamas, I. Gravalos, D. Moshou, D. Kateris, and P. Xyradakis, "A study on the effect of electronic engine speed regulator on agricultural tractor ride vibration behavior," *Journal of Terramechanics*, 2011
- [7] A. A. Kumar, V. K. Tewari, C. Gupta, and C. M. Pareek, "A device to measure wheel slip to improve the fuel efficiency of off-road vehicles," *Journal of Terramechanics*, 2017.
- [8] K. P. Lanças, A. C. Marques Filho, M. S. Moura, F. A. Damasceno, and D. R. Balestrin, "Agricultural tractor test," *Revista Ciência Agronômica*, 2021.
- [9] S. Choosumrong, R. Hataitara, and T. Pothong, "Development of smart agricultural monitoring and irrigation system using IoT and mobile applications," *The Journal of Spatial Innovation Development*, 2022.
- [10] K. Sharma and S. Shivandu, "Integrating artificial intelligence and Internet of Things (IoT) for enhanced crop monitoring and management in precision agriculture," *Sensors International*, 2024.

